

TOL. UNLESS SPECIAL SEE STANDARD TOLERANCE		Scale To Fit				
NOMINAL DIMENSION	0-30	30-100	100-200	200-400	400-1000	
0	± 0.1	± 0.2	± 0.3	± 0.5	± 1	
0.0	± 0.05	± 0.05	± 0.1	± 0.2	± 0.3	
0.00	± 0.01	± 0.02	± 0.05	± 0.05	± 0.1	

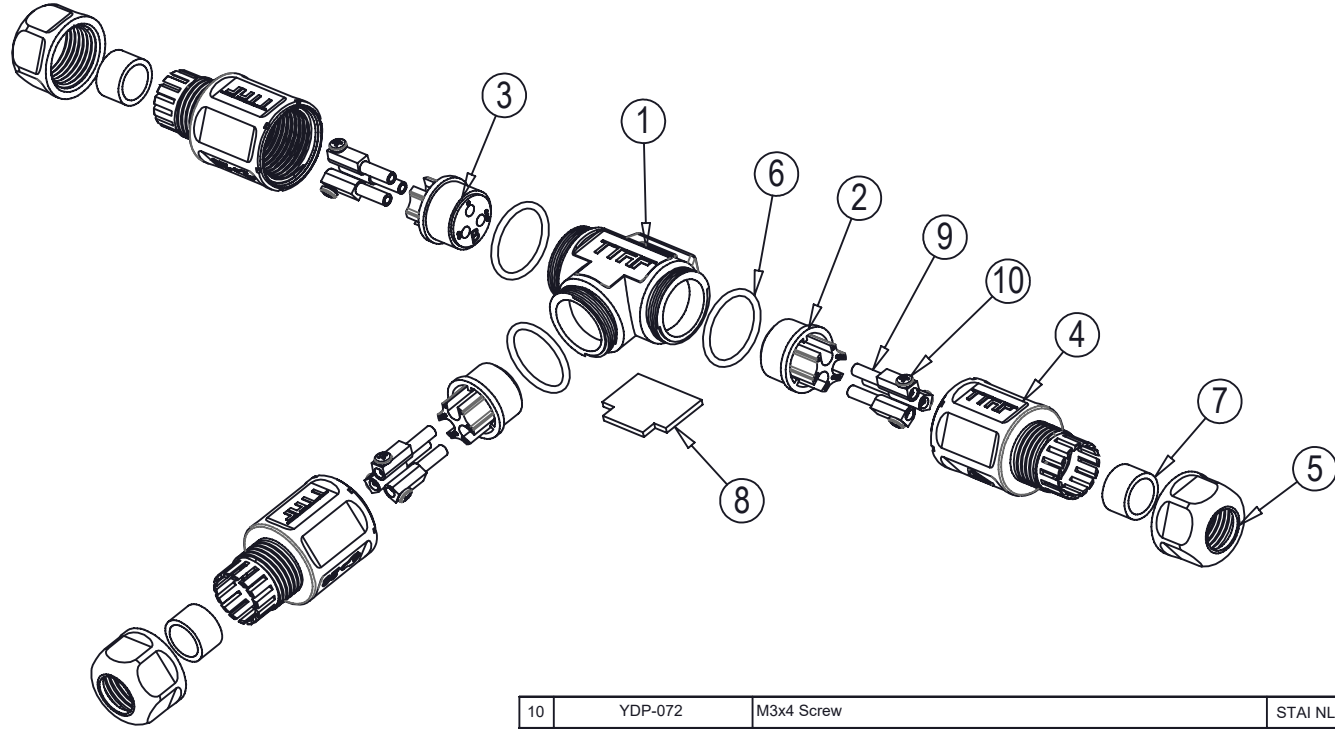

10	YDP-072	M3x4 Screw	STAI NLESS	-	9	pcs.
9	YDP-002	Pin - Nickel Plated	BRASS	-	9	pcs.
8	LD-PF416-1503-V1	T Pcb	FR4	-	1	pc.
7	YDP-004	Seal - Black	EPDM	-	3	pcs.
6	YDP-003	Oring - Red	SILICON	-	3	pcs.
5	YDP-011	Cable Gland Nut	PA6	-	3	pcs.
4	YDP-087	Cable Gland	PA6	-	3	pcs.
3	YDP-085	Pin Core / B	PA6	-	2	pcs.
2	YDP-084	Pin Core / A	PA6	-	1	pc.
1	E-GRA-00015	Body Molding	PA6	-	1	pc.

Item	Stock Code	Part / Assembly Name		Material	Size (mm)	Qty	Unit
Date	30.01.2018	Signature	Rev.	Revision Detail		Rev.Date	By
Drawn	Zafer BOLUKBASI		-			-	-
Checked	Dilek TUNCER						
Approved	Talat SAHIM						



WPT-0303M20
Exploded View

Drawing No	Scale	Sheet
-	1:2	1/13

Form No: FR.80 İYT: 05/05/2017 Rev:00 _/_/___

TOL. UNLESS SPECIAL SEE STANDARD TOLERANCE		Scale To Fit				
NOMINAL DIMENSION	0-30	30-100	100-200	200-400	400-1000	
0	± 0.1	± 0.2	± 0.3	± 0.5	± 1	
0.0	± 0.05	± 0.05	± 0.1	± 0.2	± 0.3	
0.00	± 0.01	± 0.02	± 0.05	± 0.05	± 0.1	

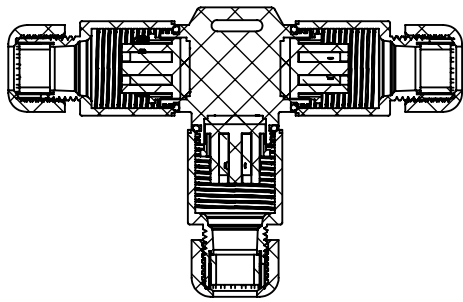

A-A
scale 1:2

the cable O.D. used varies in size
±1

max.~76,50 / min.~72

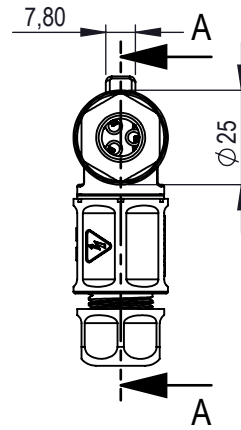
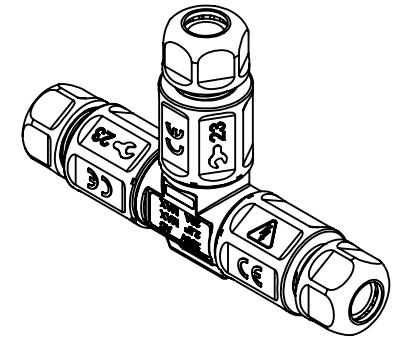
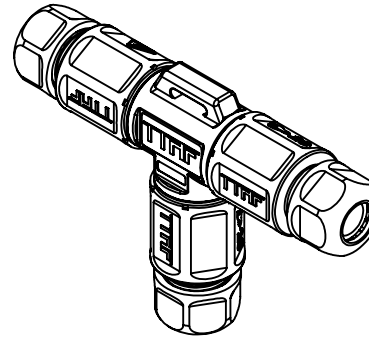
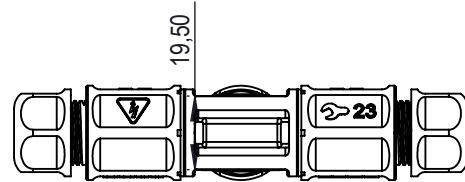
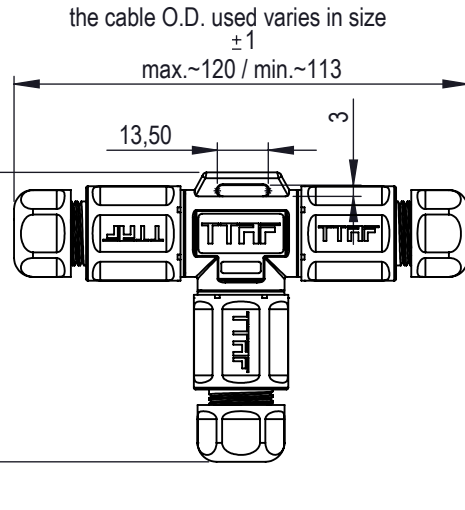
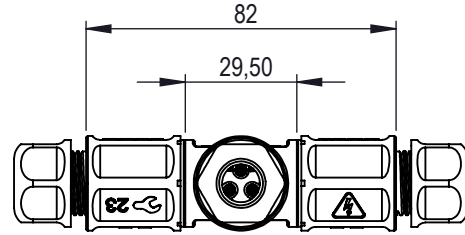

Specifications

Operation Parameters	
Voltage Rating	250VAC max
Current Rating	16A max
Min Wire Size OD	5.5mm
Max Wire Size OD	8.5mm
Max.Cable Cross Section Area	0.5 ~2.5mm ²

Technical Parameters	
Contact Resistance	10 mΩ max
Insulation Structure	500 MΩ at 500VDC
Operating Temperature	-40°C ~ +85°C
IP Rating	IP68
Mold Material	PA6
Contact/Terminal Material	Nickel Plated Brass
Oring Material(black)	Silicone
Seal Materia(black)	Epdm

Electrical Parameters	
Number of Poles	3
Current Rating	16A max
Voltage Rating	250VAC max
Durability Voltage	1500VAC @ 60 s.

Date	30.01.2018	Signature	Rev.	Revision Detail	Rev.Date	By	Drawing Description		
Drawn	Zafer BOLUKBASI		-		-	-	WPT-0303M20 Assembly View		
Checked	Dilek TUNCER								
Approved	Talat SAHIM								
							Drawing No	Scale	Sheet
							-	1:2	2/13

TOL. UNLESS SPECIAL SEE STANDARD TOLERANCE		Scale To Fit				
NOMINAL DIMENSION	0-30	30-100	100-200	200-400	400-1000	
0	± 0.1	± 0.2	± 0.3	± 0.5	± 1	
0.0	± 0.05	± 0.05	± 0.1	± 0.2	± 0.3	
0.00	± 0.01	± 0.02	± 0.05	± 0.05	± 0.1	

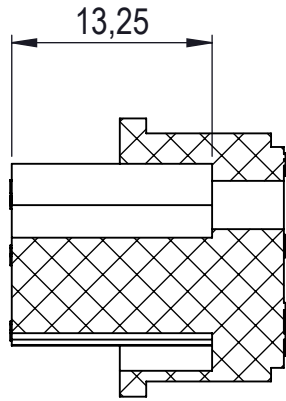

A-A
scale 2:1

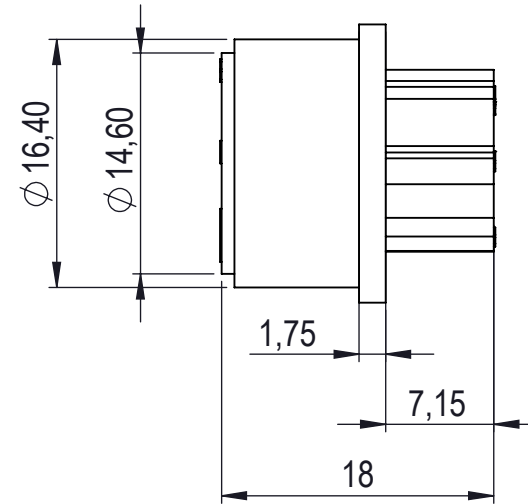
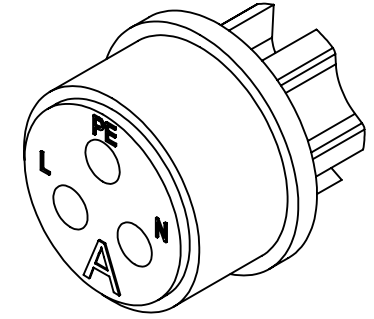
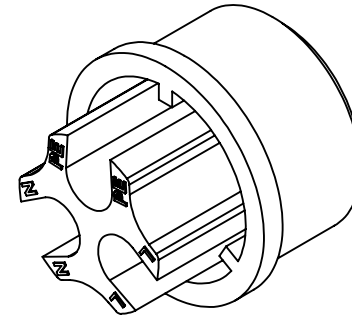
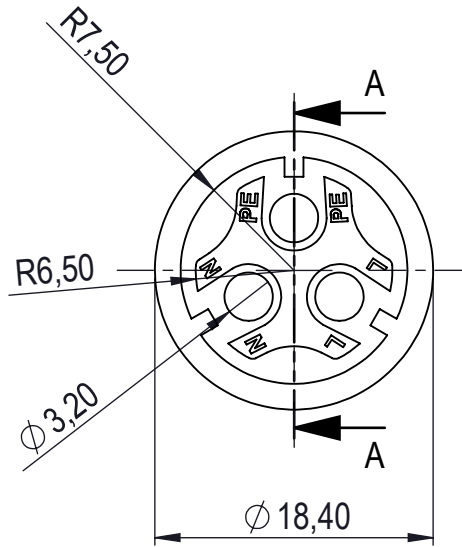

Date	30.01.2018	Signature	Rev.	Revision Detail	Rev.Date	By
Drawn	Zafer BOLUKBASI		-		-	-
Checked	Dilek TUNCER					
Approved	Talat SAHIM					



Material	PA6		
Drawing Description			
YDP-084 Pin Core "A"			
Drawing No	Scale	Sheet	
-	2:1	3/13	

TOL. UNLESS SPECIAL SEE STANDARD TOLERANCE		Scale To Fit				
NOMINAL DIMENSION	0-30	30-100	100-200	200-400	400-1000	
0	± 0.1	± 0.2	± 0.3	± 0.5	± 1	
0.0	± 0.05	± 0.05	± 0.1	± 0.2	± 0.3	
0.00	± 0.01	± 0.02	± 0.05	± 0.05	± 0.1	

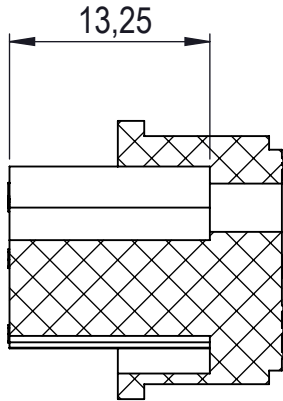

A-A
scale 2:1

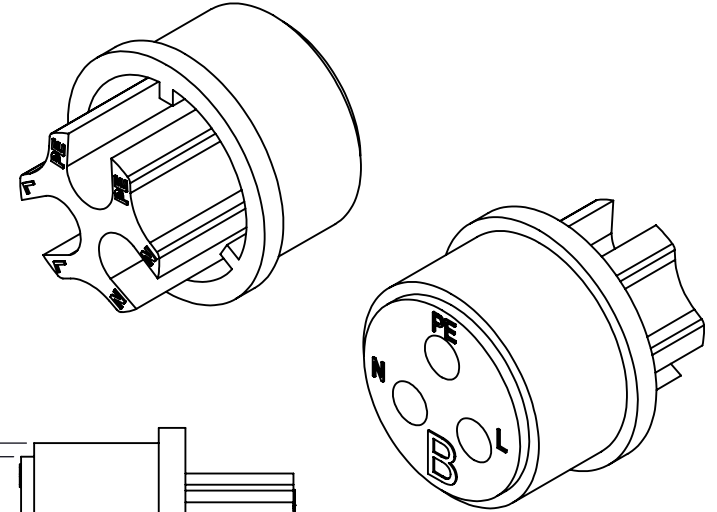
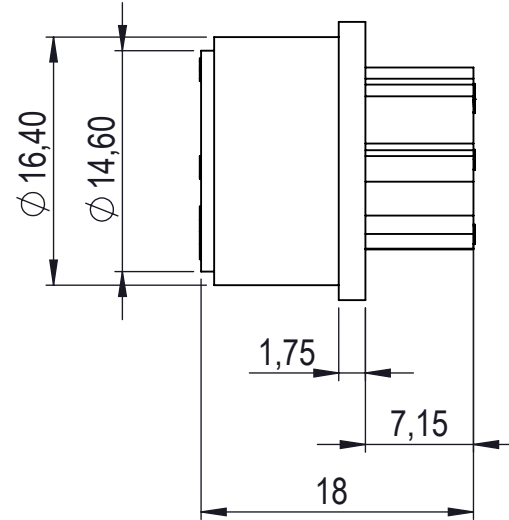
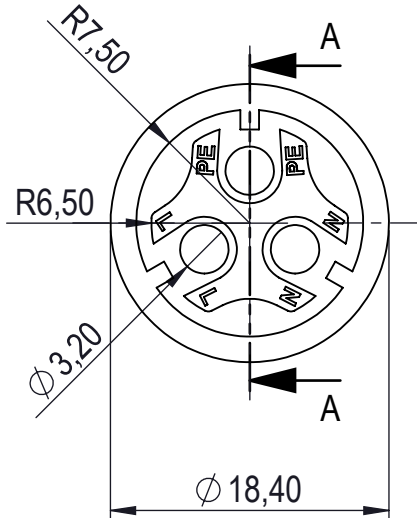

Material	PA6
----------	-----

Date	30.01.2018	Signature	Rev.	Revision Detail	Rev.Date	By	Drawing Description
Drawn	Zafer BOLUKBASI		-		-	-	YDP-085 Pin Core "B"
Checked	Dilek TUNCER						
Approved	Talat SAHIM						



Drawing No	Scale	Sheet
-	2:1	4/13

TOL. UNLESS SPECIAL SEE STANDARD TOLERANCE		Scale To Fit			
NOMINAL DIMENSION	0-30	30-100	100-200	200-400	400-1000
0	± 0.1	± 0.2	± 0.3	± 0.5	± 1
0.0	± 0.05	± 0.05	± 0.1	± 0.2	± 0.3
0.00	± 0.01	± 0.02	± 0.05	± 0.05	± 0.1

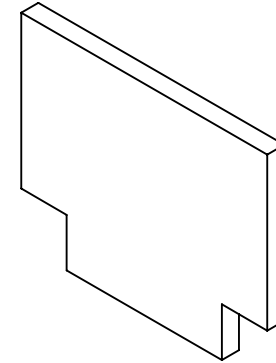
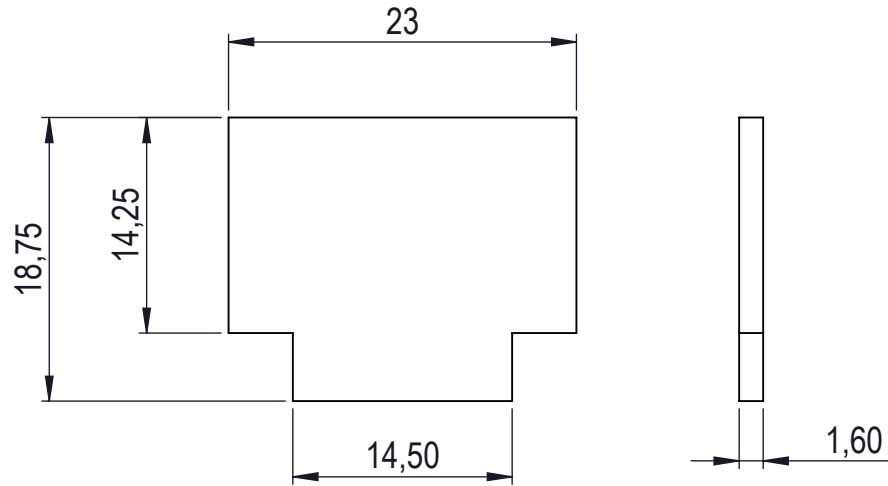



Date	30.01.2018	Signature	Rev.	Revision Detail		Rev.Date	By
Drawn	Zafer BOLUKBASI		-			-	-
Checked	Dilek TUNCER						
Approved	Talat SAHIM						

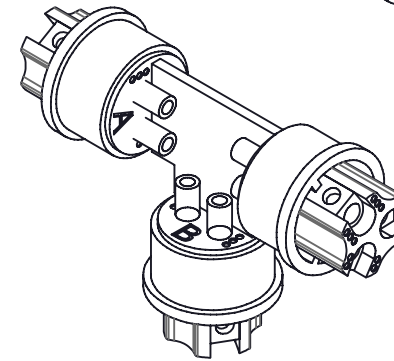
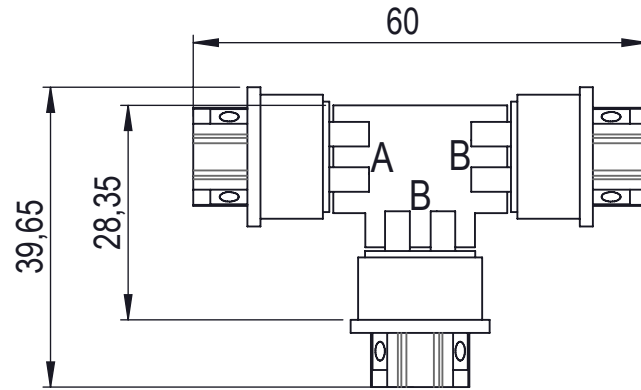
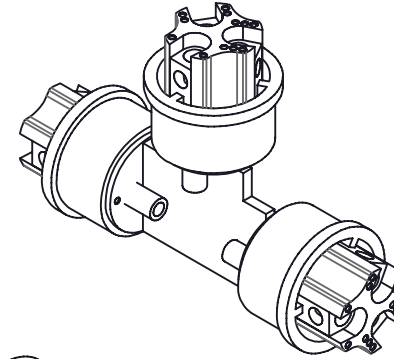
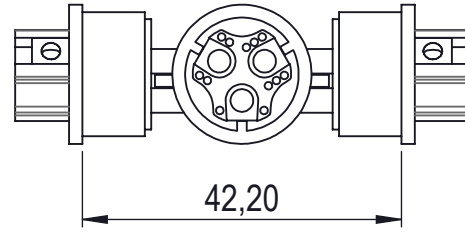

Material		FR4
Drawing Description		
LD-PF416-1503-V1 Pcb		
Drawing No	Scale	Sheet
-	2:1	6/13

TOL. UNLESS SPECIAL SEE STANDARD TOLERANCE		Scale To Fit			
NOMINAL DIMENSION	0-30	30-100	100-200	200-400	400-1000
0	± 0.1	± 0.2	± 0.3	± 0.5	± 1
0.0	± 0.05	± 0.05	± 0.1	± 0.2	± 0.3
0.00	± 0.01	± 0.02	± 0.05	± 0.05	± 0.1



Date	30.01.2018	Signature	Rev.	Revision Detail		Rev.Date	By	Drawing Description		
Drawn	Zafer BOLUKBASI		-			-	-	WPT-0303M20 Pcb Assembly		
Checked	Dilek TUNCER									
Approved	Talat SAHIM									
								Drawing No	Scale	Sheet
								-	1:1	7/13

TOL. UNLESS SPECIAL SEE STANDARD TOLERANCE		Scale To Fit				
NOMINAL DIMENSION	0-30	30-100	100-200	200-400	400-1000	
0	±0.1	±0.2	±0.3	±0.5	±1	
0.0	±0.05	±0.05	±0.1	±0.2	±0.3	
0.00	±0.01	±0.02	±0.05	±0.05	±0.1	

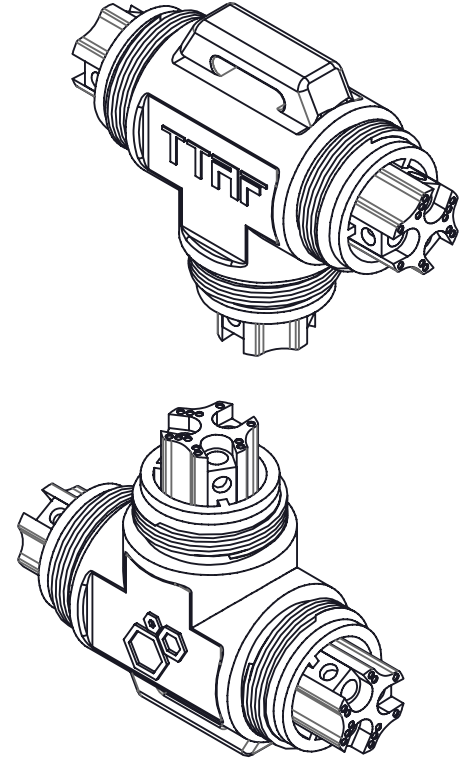
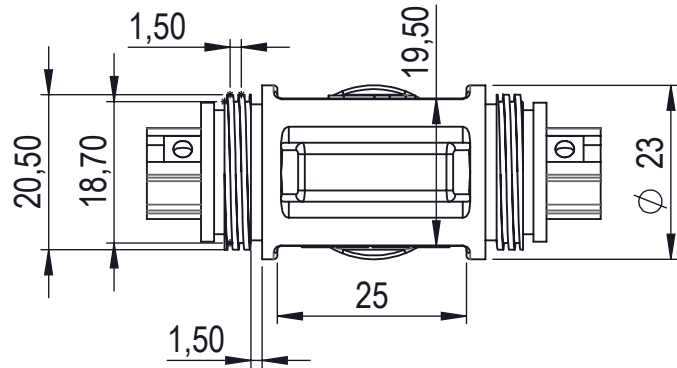
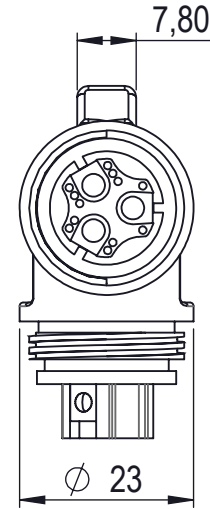
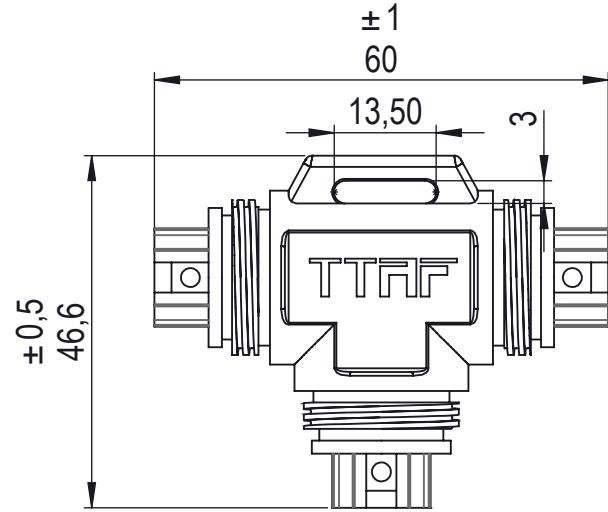

Date	30.01.2018	Signature	Rev.	Revision Detail	Rev.Date	By	Drawing Description		
Drawn	Zafer BOLUKBASI		-		-	-	WPT-0303M20 Body Molding		
Checked	Dilek TUNCER								
Approved	Talat SAHIM								
							Drawing No	Scale	Sheet
							-	1:1	8/13

TOL. UNLESS SPECIAL SEE STANDARD TOLERANCE		Scale To Fit				
NOMINAL DIMENSION	0-30	30-100	100-200	200-400	400-1000	
0	± 0.1	± 0.2	± 0.3	± 0.5	± 1	
0.0	± 0.05	± 0.05	± 0.1	± 0.2	± 0.3	
0.00	± 0.01	± 0.02	± 0.05	± 0.05	± 0.1	

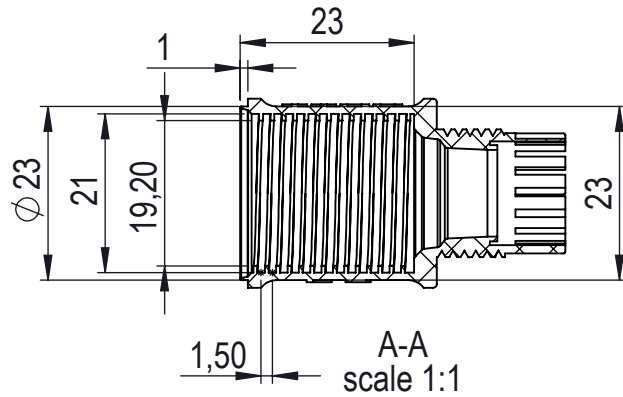
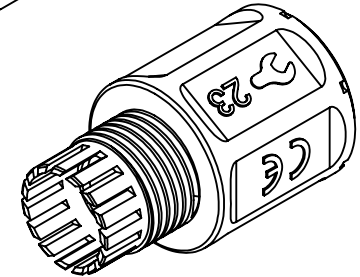
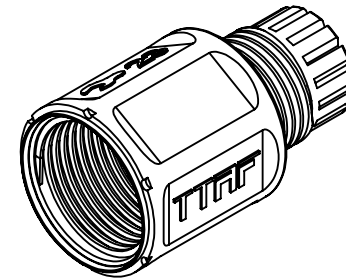
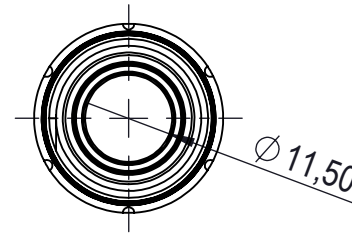
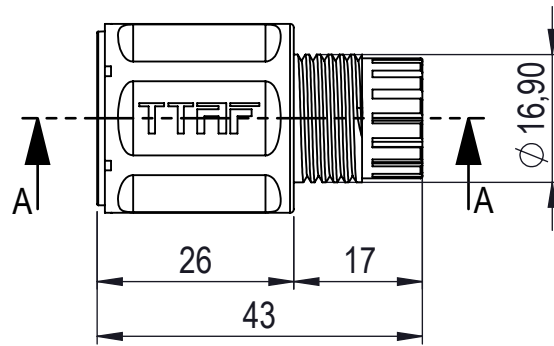
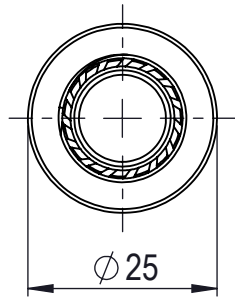

Date	29.01.2018	Signature	Rev.	Revision Detail	Rev.Date	By
Drawn	Zafer BOLUKBASI		-		-	-
Checked	Dilek TUNCER					
Approved	Talat SAHIM					

Material PA6

Drawing Description

YDP-087
Cable Gland

Drawing No	Scale	Sheet
-	1:1	9/13



TOL. UNLESS SPECIAL SEE STANDARD TOLERANCE		Scale To Fit				
NOMINAL DIMENSION	0-30	30-100	100-200	200-400	400-1000	
0	± 0.1	± 0.2	± 0.3	± 0.5	± 1	
0.0	± 0.05	± 0.05	± 0.1	± 0.2	± 0.3	
0.00	± 0.01	± 0.02	± 0.05	± 0.05	± 0.1	

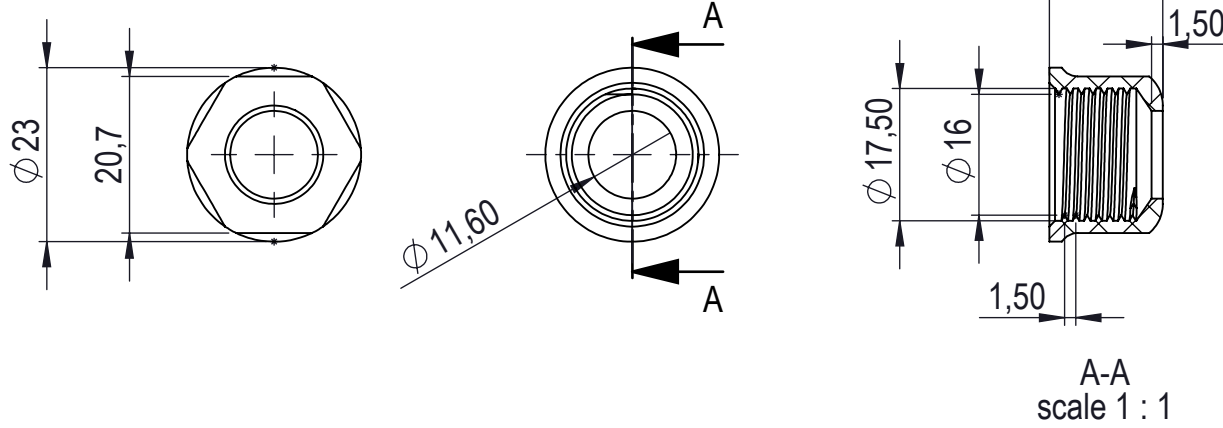
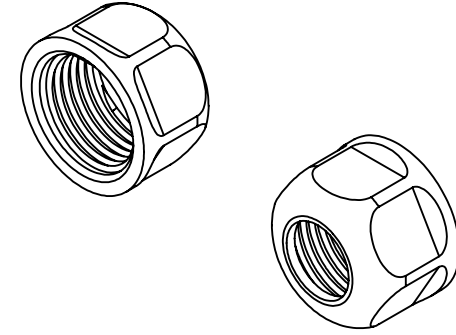

Material	PA6
----------	-----

Date	Signature	Rev.	Revision Detail	Rev.Date	By
29.01.2018	Zafer BOLUKBASI	-	-	-	-
	Dilek TUNCER				
	Talat SAHIM				

Drawing Description		
---------------------	--	--

YDP-011
Cable Gland Nut

Drawing No	Scale	Sheet
-	1:1	10/13



TOL. UNLESS SPECIAL SEE STANDARD TOLERANCE		Scale To Fit			
NOMINAL DIMENSION	0-30	30-100	100-200	200-400	400-1000
0	± 0.1	± 0.2	± 0.3	± 0.5	± 1
0.0	± 0.05	± 0.05	± 0.1	± 0.2	± 0.3
0.00	± 0.01	± 0.02	± 0.05	± 0.05	± 0.1

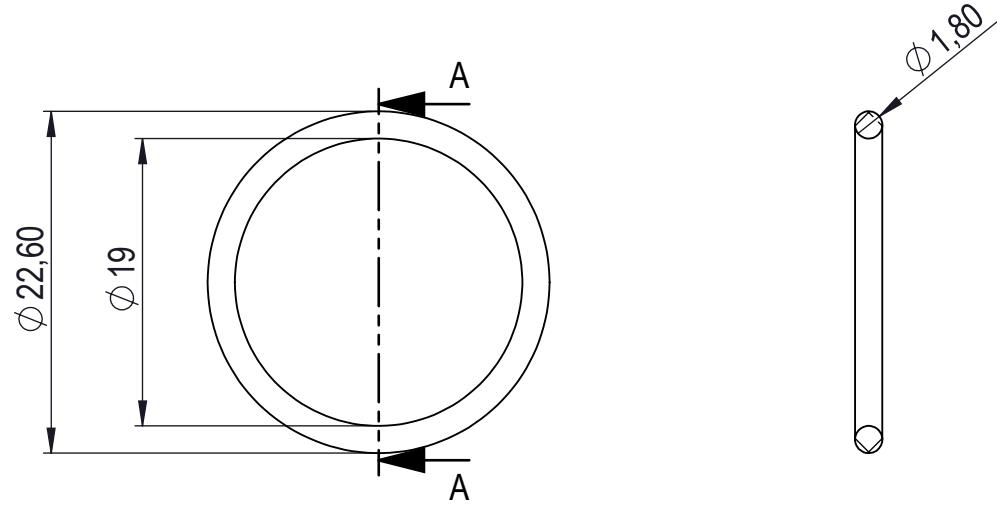

A-A
scale 2:1

Date	30.01.2018	Signature	Rev.	Revision Detail	Rev.Date	By	Drawing Description		
Drawn	Zafer BOLUKBASI		-		-	-	YDP-003 Oring(Red)		
Checked	Dilek TUNCER								
Approved	Talat SAHIM								
							Drawing No	Scale	Sheet
							-	2:1	11/13

Material Silicon

TOL. UNLESS SPECIAL SEE STANDARD TOLERANCE		Scale To Fit			
NOMINAL DIMENSION	0-30	30-100	100-200	200-400	400-1000
0	± 0.1	± 0.2	± 0.3	± 0.5	± 1
0.0	± 0.05	± 0.05	± 0.1	± 0.2	± 0.3
0.00	± 0.01	± 0.02	± 0.05	± 0.05	± 0.1

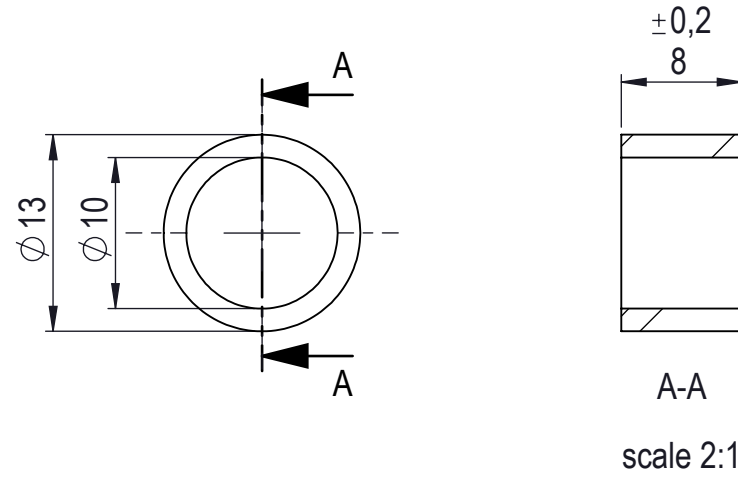

Material	EPDM
----------	------

Date	29.01.2018	Signature	Rev.	Revision Detail	Rev.Date	By	Drawing Description
Drawn	Zafer BOLUKBASI		-		-	-	YDP-004 Seal(Black)
Checked	Dilek TUNCER						
Approved	Talat SAHIM						



Drawing No	Scale	Sheet
-	2:1	12/13

TOL. UNLESS SPECIAL SEE STANDARD TOLERANCE		Scale To Fit			
NOMINAL DIMENSION	0-30	30-100	100-200	200-400	400-1000
0	± 0.1	± 0.2	± 0.3	± 0.5	± 1
0.0	± 0.05	± 0.05	± 0.1	± 0.2	± 0.3
0.00	± 0.01	± 0.02	± 0.05	± 0.05	± 0.1

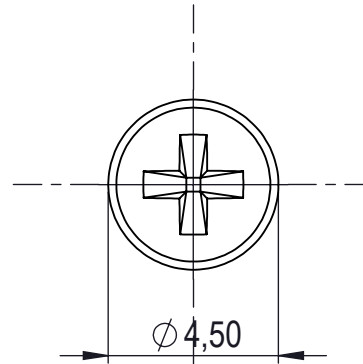
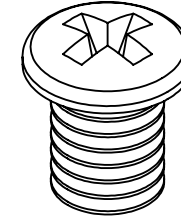
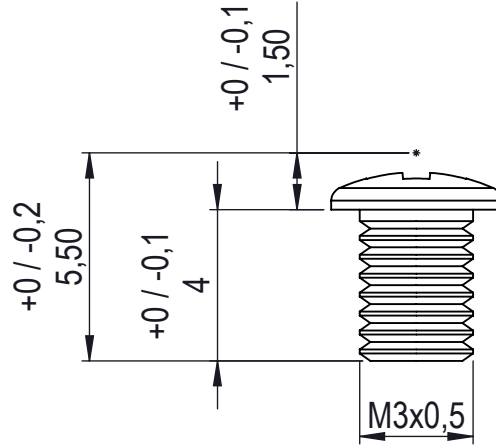

Material **STAINLESS**

Date	Signature	Rev.	Revision Detail	Rev.Date	By
29.01.2018	Zafer BOLUKBASI	-	-	-	-
	Dilek TUNCER				
	Talat SAHIM				

Drawing Description

YDP-072
M3x4mm Screw

Drawing No	Scale	Sheet
TET-102	5:1	13/13

